

CAD FILE:

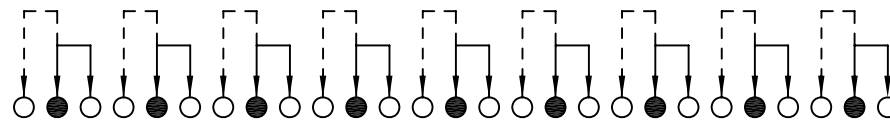

SCHMATIC (NON-SHORTING)

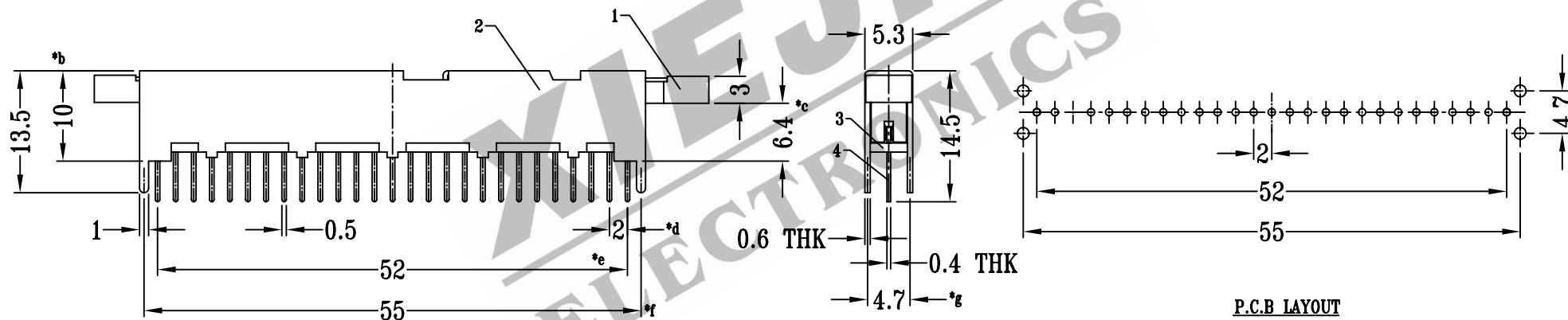
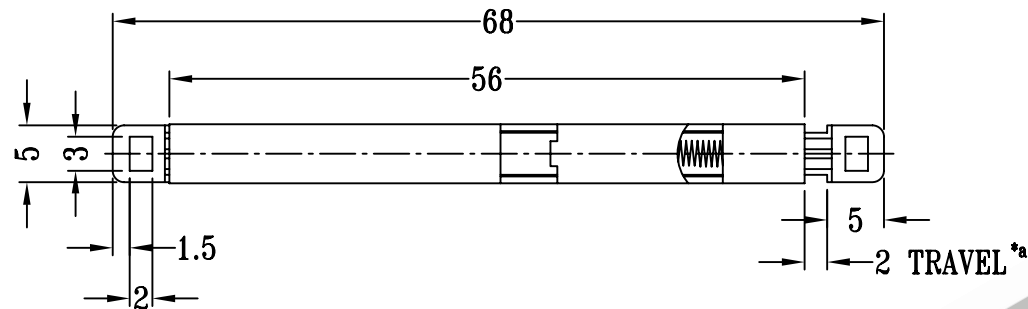

P.C.B LAYOUT

注:带"\*"表示关键尺寸(7个)

				TOLERANCE UNLESS SPECIFIED		SHENZHEN XIEJIA ELECTRONICS CO.,LTD.				
				WITHIN : 1.5±0.1mm		ISSUE	DATE	DESCRIPTIONS OF REVISION		APPD.
				OVER : 1.5±0.2mm						
8										
7										
6	SPRING	STEEL WIRE	1	TEMPER						
5	CONTACT CLIP	PBS STRIP	9	Ag PLATED						
4	TERMINAL	BRASS STRIP	27	Ag PLATED OVER Ni PLATED	TITLE : PUSH SWITCH		UNIT : mm	DRWG NO.: XJ-DR-PS92D01-00		
3	BASE	PHENOLIC RESIN	1	NATURAL	MODEL: PS-92D01		SCALE: 3:2	DWN.	ZHOUYU	2003-8-24
2	FRAME	STEEL STRIP	1	Ni PLATED	ALL MATERIALS MUST BE COMPLIANT TO ROHS			CHK'D	FANGYING	2003-8-24
1	KNOB	ABS/PC	1	BLACK				APPD.	KANGXINAN	2003-8-24
NO.	PARTS	MATERIALS	Q'TY	FINISH						